

# BOTTOM MOUNT COVER LIFTER

## INSTRUCTIONS



### PARTS LIST

DESCRIPTION	QTY
A. Top Corner Piece with Foam Grips	2
B. Bottom Corner Pieces	2
AB. Bottom Corner Pieces (contracted)	4
Ca. Bridge Arm	4
Cb. Bridge arm (contracted)	4
D. Retaining Chain	2
E. Chain Bracket	2
F. Mounting Blocks	3
G. Small Black Dome Caps	56
H. Towel Holder	1
I. #8 x 1 1/4" Wood Screws	12
J. #10 x 5/8" Metal Screws	56
K. #8 x 5/8" Wood Screws (Not Shown)	6

**Tools Needed:** Power/Cordless Drill with phillips bit and a tape measure.

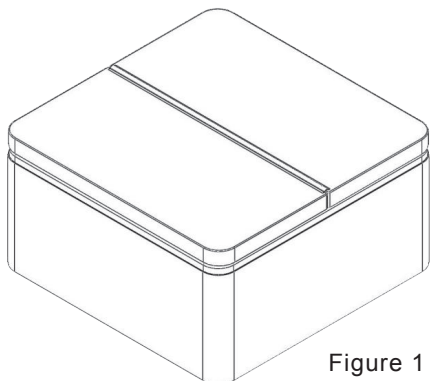
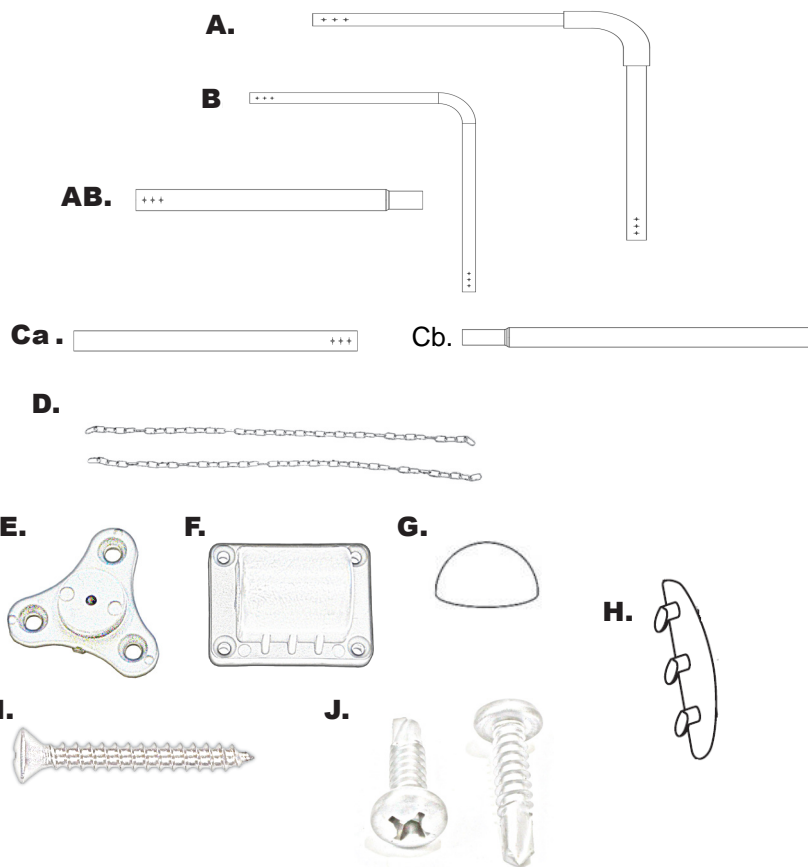

Figure 1

### Installation Instructions

- 1 Position the spa cover in the closed position on the spa, making sure that all four corners are square on the spa. (See Figure 1).

# 2

Using the **#8 x 1-1/4" mounting screws (I)**, attach the **Mounting Brackets (F)** to the back side of the spa. Space the Mounting Brackets evenly across the width of the spa. (See Figure 2).

**CAUTION:** To prevent splitting of wood cabinet, pre-drill holes with a 1/16" drill bit.

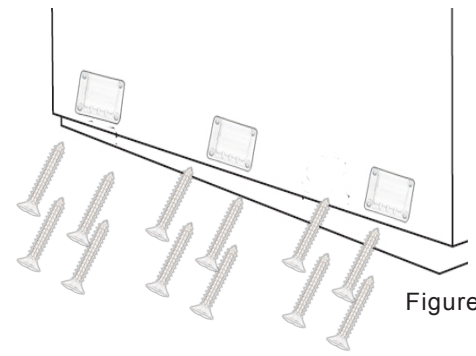

Figure 2

# 3

Insert the long end of the **Lower Corner Arms (B)** into the **Mounting Brackets** to the back side of the spa (See Figure 3). Next, insert the **Top Corner Arms (A)** into the **Center Bridge Arm (C)**. Then join the **Top Corner Arm** sections to the **Lower Corner Arm** sections, sliding the short portion of the **Corner Arms** into the **Side Bridge Arms (C)**.

**Note:** Place a **#10 self tapping screw (J)** into the **Lower Support Arm** next to the outside edge of each **Mounting Bracket**. This will prevent the Lifter from sliding left or right.

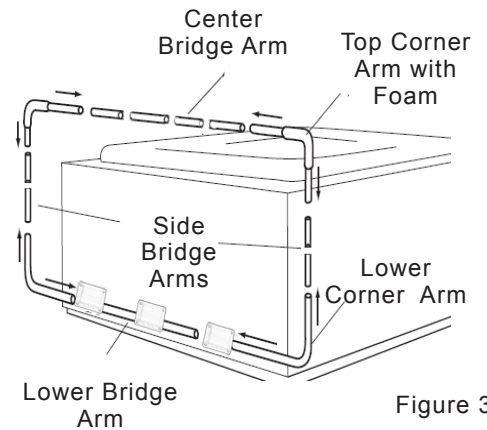

Figure 3

# 4

With the top section of the Lifter laying on the spa cover. Adjust and center the **Center Bridge Arm** and **Top Corner Support Arms** so that the **Bridge Arm** is lying parallel to the spa cover's hinge about 1/2" away (See Figure 4). Position the **Side Bridge Arms** in the center of the **Top and Lower Corner Arms** and attach with the **#10 self-tapping screws (J)**. Using the **#10 self-tapping screws**, fasten all **Corner Arms** and **Bridge Arms** together.

**Note:** Be sure to rotate the **Top Bridge Arm** so that the inserted screws are at a horizontal angle with the heads facing the back of the spa. Repeat this procedure for the **Lower Bridge Arm**.

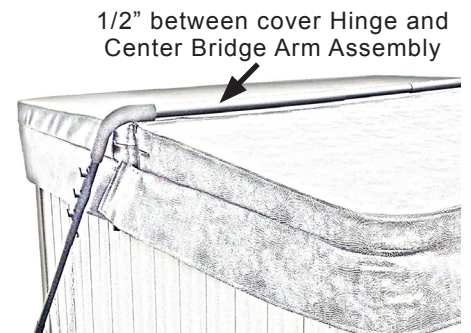

Figure 4

# 5

After assembling the Lifter, move to the upright and vertical position. Using a **#8 x 5/8" mounting screw**, attach the **Chain Bracket** to the wood skirt of the spa. Then using a **#10 mounting screw**, attach the end of the chain to the center of the **Chain Bracket**. Next, position the opposite end of the **Retaining Chain** on the **Side Bridge Arm** so that it is in a horizontal, level position and attach using a **#10 self-tapping screw** (See Figure 5).

Snap the black plastic **Dome Screw Caps (G)** on.

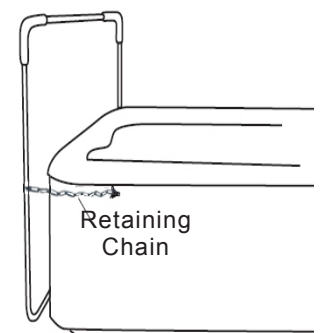

Figure 5

# 6

Attach the provided 3 hook **Towel Holder (H)** on the preferred side of your Lifter by simply snapping it into place and inserting the middle self-tapping screw (See Figure 6).

**To open your spa cover**, flip your spa cover back over the support bar that lays across the cover by the cover seam. Taking hold of the top corner of the lifter, lift the bar towards the back of the spa until the spa cover is hanging in a slightly over-vertical position.

**To close your spa cover**, take hold of the top corner of the lifter and pull down towards the middle of the spa. Once the spa cover is lying on the spa, take hold of the top half of the cover pulling it up and forward to close the cover completely over the spa.

**DO NOT USE** your cover lifter in high wind conditions (more than 10 mph). Injury from the spa cover being blown over and impacting the spa user can occur.

**DO NOT** leave lift open when not in use.

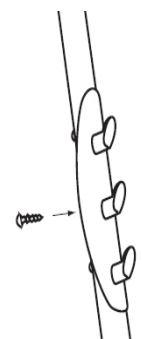

Figure 6

HOW TO USE